

ENGINEERING TEST REPORT

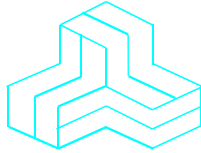

**HF/VHF/UHF All Mode Transceiver
Model No.: IC-7000**

FCC ID: AFJ242700

Applicant:

ICOM Incorporated
1-1-32, Kamiminami, Hirano-ku
Osaka, Japan, 547-0003

Tested in Accordance With

**Federal Communications Commission (FCC)
47 CFR, Part 15, Subpart B
Scanning Receivers Operating in the Frequency Bands
30 kHz – 199.999999 MHz and 400-470 MHz**

UltraTech's File No.: ICOM-118F15B121

This Test report is Issued under the Authority of
Tri M. Luu, Professional Engineer,
Vice President of Engineering
UltraTech Group of Labs

Date: November 8, 2005



Report Prepared by: Dan Huynh

Tested by: Wayne Wu, EMI/RFI Technician

Issued Date: November 8, 2005

Test Dates: October 11 - November 7, 2005

- *The results in this Test Report apply only to the sample(s) tested, and the sample tested is randomly selected.*
- *This report must not be used by the client to claim product endorsement by NVLAP or any agency of the US Government.*

UltraTech

3000 Bristol Circle, Oakville, Ontario, Canada, L6H 6G4
Tel.: (905) 829-1570 Fax.: (905) 829-8050

Website: www.ultratech-labs.com, Email: vic@ultratech-labs.com, Email: tri@ultratech-labs.com



TABLE OF CONTENTS

EXHIBIT 1.	SUBMITTAL CHECK LIST	1
EXHIBIT 2.	INTRODUCTION.....	2
2.1.	SCOPE	2
2.2.	RELATED SUBMITTAL(S)/GRANT(S).....	2
2.3.	NORMATIVE REFERENCES	2
EXHIBIT 3.	PERFORMANCE ASSESSMENT	3
3.1.	CLIENT INFORMATION	3
3.2.	EQUIPMENT UNDER TEST (EUT) INFORMATION	3
3.3.	EUT'S TECHNICAL SPECIFICATIONS	4
3.4.	LIST OF EUT'S PORTS.....	4
3.5.	ANCILLARY EQUIPMENT	4
3.6.	DRAWING OF TEST SETUP	5
EXHIBIT 4.	EUT OPERATING CONDITIONS AND CONFIGURATIONS DURING TESTS.....	2
4.1.	CLIMATE TEST CONDITIONS	2
4.2.	OPERATIONAL TEST CONDITIONS & ARRANGEMENT FOR TEST SIGNALS	2
EXHIBIT 5.	SUMMARY OF TEST RESULTS.....	7
5.1.	LOCATION OF TESTS	7
5.2.	APPLICABILITY & SUMMARY OF EMC EMISSION TEST RESULTS	7
5.3.	MODIFICATIONS REQUIRED FOR COMPLIANCE	7
EXHIBIT 6.	MEASUREMENTS, EXAMINATIONS & TEST DATA FOR EMC EMISSIONS	8
6.1.	TEST PROCEDURES	8
6.2.	MEASUREMENT UNCERTAINTIES	8
6.3.	MEASUREMENT EQUIPMENT USED	8
6.4.	POWER LINE CONDUCTED EMISSIONS [§ 15.107(a)].....	9
6.5.	RADIATED EMISSIONS FROM CLASS B UNINTENTIONAL RADIATORS (DIGITAL DEVICES) [§ 15.109(a)].....	12
6.6.	RECEIVER SPURIOUS/HARMONIC RADIATED EMISSIONS [§ 15.109(a)].....	15
6.7.	RECEIVER ANTENNA POWER SPURIOUS/HARMONIC CONDUCTED EMISSIONS [§15.111(a)].....	18
6.8.	REQUIREMENTS FOR SCANNING RECEIVERS [§ 15.121]	31
6.9.	SCANNING RECEIVERS CELLULAR BAND REJECTION [§ 15.121(b)].....	33
EXHIBIT 7.	MEASUREMENT UNCERTAINTY.....	36
7.1.	LINE CONDUCTED EMISSION MEASUREMENT UNCERTAINTY.....	36
7.2.	RADIATED EMISSION MEASUREMENT UNCERTAINTY	37

EXHIBIT 1. SUBMITTAL CHECK LIST

Annex No.	Exhibit Type	Description of Contents	Quality Check (OK)
--	Test Report	<ul style="list-style-type: none"> ▪ Exhibit 1: Submittal check lists ▪ Exhibit 2: Introduction ▪ Exhibit 3: Performance Assessment ▪ Exhibit 4: EUT Operation and Configuration during Tests ▪ Exhibit 5: Summary of test Results ▪ Exhibit 6: Measurement Data ▪ Exhibit 7: Measurement Uncertainty ▪ Exhibit 8: Measurement Methods 	OK
1	Test Setup Photos	Radiated Emissions Test Setup Photos	OK
2	External Photos of EUT	External EUT Photos	OK
3	Internal Photos of EUT	Internal EUT Photos	OK
4	Cover Letters	<ul style="list-style-type: none"> ▪ Cover Letter for Certification Request. ▪ Letter from the Applicant to appoint Ultratech to act as an agent ▪ Letter from the Applicant to request for Confidentiality Filing 	OK
5	Attestation Statements	<ul style="list-style-type: none"> ▪ Manufacturer Attestation Letter ▪ Part 2.1033(b)(10) for Scanning Receiver 	OK
6	ID Label/Location Info	ID Label and Location	OK
7	Block Diagrams	Block Diagram	OK
8	Schematic Diagrams	Schematics	OK
9	Operational Description	IC-7000 Circuit Description	OK
10	RF Exposure Info	N/A	N/A
11	Users Manual	Instruction Manual	OK

EXHIBIT 2. INTRODUCTION

2.1. SCOPE

Reference:	FCC Part 15, Subpart B, Sections 15.107, 15.109, 15.111 & 15.121
Title:	Code of Federal Regulations (CFR), Title 47, Telecommunication, Part 15
Purpose of Test:	To gain FCC Certification Authorization for Scanning Receivers Operating in 30 kHz – 199.999999 MHz and 400-470 MHz Bands.
Test Procedures:	Both conducted and radiated emissions measurements were conducted in accordance with American National Standards Institute ANSI C63.4 - American National Standard for Methods of Measurement of Radio-Noise Emissions from Low-Voltage Electrical and Electronic Equipment in the Range of 9 kHz to 40 GHz.
Environmental Classification:	Commercial, industrial or business environment.

2.2. RELATED SUBMITTAL(S)/GRANT(S)

None.

2.3. NORMATIVE REFERENCES

Publication	Year	Title
FCC CFR Parts 0-15	2005	Code of Federal Regulations (CFR), Title 47 - Telecommunication
ANSI C63.4	2004	American National Standard for Methods of Measurement of Radio-Noise Emissions from Low-Voltage Electrical and Electronic Equipment in the Range of 9 kHz to 40 GHz
CISPR 22 +A1 EN 55022	2003-04-10 2004-10-14 2003	Limits and Methods of Measurements of Radio Disturbance Characteristics of Information Technology Equipment
CISPR 16-1-1	2003	Specification for radio disturbance and immunity measuring apparatus and methods. Part 1-1: Measuring Apparatus
CISPR 16-2-1	2003	Specification for radio disturbance and immunity measuring apparatus and methods. Part 2-1: Conducted disturbance measurement
CISPR 16-2-3	2003	Specification for radio disturbance and immunity measuring apparatus and methods. Part 2-3: Radiated disturbance measurement

EXHIBIT 3. PERFORMANCE ASSESSMENT

3.1. CLIENT INFORMATION

APPLICANT	
Name:	ICOM Incorporated
Address:	1-1-32, Kamiminami Hirano-ku, Osaka Japan, 547-003
Contact Person:	Mr. Takashi Aoki Phone #: +81-66-793-5302 Fax #: +81-66-793-0013 Email Address: export@icom.co.jp

MANUFACTURER	
Name:	ICOM Incorporated
Address:	1-1-32, Kamiminami Hirano-ku, Osaka Japan, 547-0003
Contact Person:	Mr. Takashi Aoki Phone #: +81-66-793-5302 Fax #: +81-66-793-0013 Email Address: export@icom.co.jp

3.2. EQUIPMENT UNDER TEST (EUT) INFORMATION

The following information (with the exception of the Date of Receipt) has been supplied by the applicant.

Brand Name:	ICOM Incorporated
Product Name:	HF/VHF/UHF All Mode Transceiver
Model Name or Number:	IC-7000
Serial Number:	Test sample.
Type of Equipment:	Scanning Receivers
Accessories:	Icom Hand Microphone, Model HM-151
Power input source:	13.8 V DC \pm 15 %

3.3. EUT'S TECHNICAL SPECIFICATIONS

RECEIVER	
Equipment Type:	Mobile
Power Supply Requirement:	13.8 V DC
Operating Frequency Range:	30 kHz – 199.999999 MHz and 400-470.000000 MHz
RF Input Impedance:	50 Ohms

3.4. LIST OF EUT'S PORTS

Port Number	EUT's Port Description	Number of Identical Ports	Connector Type	Cable Type (Shielded/Non-shielded)
1	Electronic Keyer Jack [KEY]	1	Jack	Shielded
2	Accessory Socket [ACC]	1	13-pin DIN	Shielded
3	Data Socket [DATA]	1	6-pin mini-DIN	Shielded
4	Video Out Jack [VOUT]	1	3.5 mm Jack	Shielded
5	CI-V Remote Control Jack [REMOTE]	1	Mini plug	Shielded
6	Tuner Control Socket [TUNER]	1	4-pin TB	Non-shielded
7	RTTY Jack [RTTY]	1	Mini plug	Shielded
8	External Speaker Jack [EXT SP]	1	Mini plug	Shielded
9	Microphone Connector [MIC]	1	8-pin RJ-45	Non-shielded
10	Antenna Connector [ANT1]	1	PL-259	Shielded
11	Antenna Connector [ANT2]	1	PL-259	Shielded
12	DC Power Socket	1	4-pin TB	Non-shielded

3.5. ANCILLARY EQUIPMENT

The EUT was tested while connected to the following representative configuration of ancillary equipment necessary to exercise the ports during tests:

Ancillary Equipment # 1	
Description:	Hand Microphone
Brand name:	ICOM
Model Name or Number:	HM-151
Serial Number:	N/A
Cable Type:	Shielded

3.6. DRAWING OF TEST SETUP

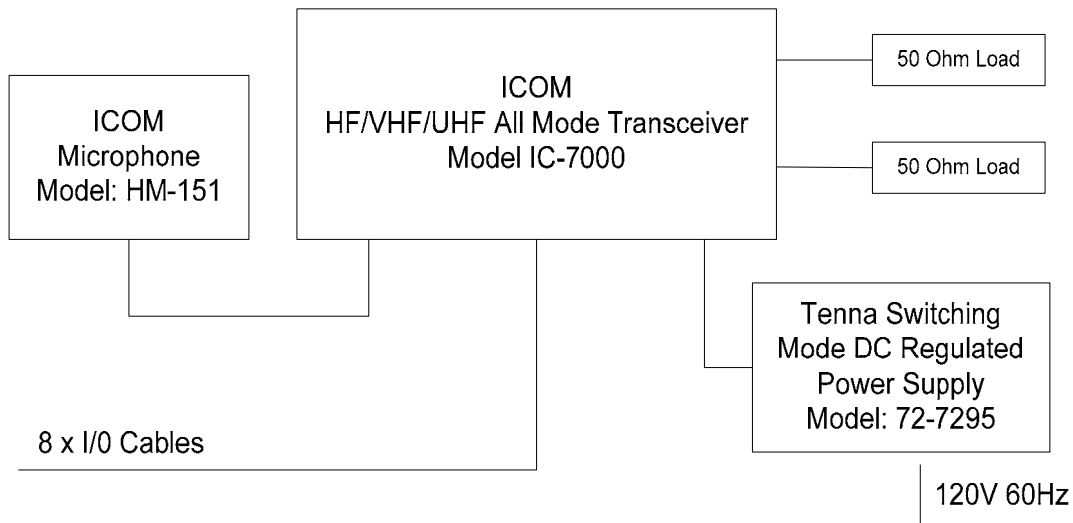

EXHIBIT 4. EUT OPERATING CONDITIONS AND CONFIGURATIONS DURING TESTS

4.1. CLIMATE TEST CONDITIONS

The climate conditions of the test environment are as follows:

Temperature:	21oC
Humidity:	51%
Pressure:	102 kPa
Power input source:	13.8 V DC

4.2. OPERATIONAL TEST CONDITIONS & ARRANGEMENT FOR TEST SIGNALS

Operating Modes:	The receiver was operated in the normal intended mode during testing
Special Test Software:	None
Special Hardware Used:	None
Receiver Test Antenna:	The EUT's was tested with its antenna attached for radiated emissions.

Receiver Test Signals	
Frequency Band(s):	35 kHz - 199.999999 MHz 400 - 470 MHz
Test Frequency(ies): (Near lowest, near middle & near highest frequencies in the frequency range of operation.)	30 MHz, 115 MHz and 199.999999 MHz 400 MHz, 435 MHz and 470 MHz

EXHIBIT 5. SUMMARY OF TEST RESULTS

5.1. LOCATION OF TESTS

All of the measurements described in this report were performed at Ultratech Group of Labs located in the city of Oakville, Province of Ontario, Canada.

- AC Power Line Conducted Emissions were performed in UltraTech's shielded room, 24'(L) x 16'(W) x 8'(H).
- Radiated Emissions were performed at the Ultratech's 3-10 TDK Semi-Anechoic Chamber situated in the Town of Oakville, province of Ontario. This test site been calibrated in accordance with ANSI C63.4, and found to be in compliance with the requirements of Sec. 2.948 of the FCC Rules. The descriptions and site measurement data of the Oakville 3-10 TDK Semi-Anechoic Chamber has been filed with FCC office (FCC File No.: 31040/SIT 1300B3) and Industry Canada office (Industry Canada File No.: IC2049-1). Last Date of Site Calibration: June. 20, 2005.

5.2. APPLICABILITY & SUMMARY OF EMC EMISSION TEST RESULTS

FCC Part 15, Subpart B	Test Requirements	Compliance (Yes/No)
15.107(a)	Power Line Conducted Emissions Measurements	Yes
15.109(a)	Radiated Emissions from Scanning Receivers & Class B Digital Device	Yes
15.111(a)	Receiver Antenna Power Conducted Emissions for Non-Integral Antenna Port	Yes
15.121	Requirements for Scanning Receivers	Yes

5.3. MODIFICATIONS REQUIRED FOR COMPLIANCE

None.

EXHIBIT 6. MEASUREMENTS, EXAMINATIONS & TEST DATA FOR EMC EMISSIONS

6.1. TEST PROCEDURES

Please refer to Ultratech Test Procedures, File# ULTR-P001-2004 for test procedures.

6.2. MEASUREMENT UNCERTAINTIES

The measurement uncertainties stated were calculated in accordance with requirements of UKAS Document LAB 34 with a confidence level of 95%. Please refer to Exhibit 7 for Measurement Uncertainties.

6.3. MEASUREMENT EQUIPMENT USED

The measurement equipment used complied with the requirements of the Standards referenced in the Methods & Procedures ANSI C63.4 and CIPSR 16-1-1.

6.4. POWER LINE CONDUCTED EMISSIONS [§ 15.107(a)]

6.4.1. Limits

The equipment shall meet the limits of the following table:

Frequency of emission (MHz)	Conducted Limits (dB μ V)	
	Quasi-peak	Average
0.15–0.5	66 to 56*	56 to 46*
0.5–5	56	46
5–30	60	50

*Decreases with the logarithm of the frequency

6.4.2. Method of Measurements

See to Ultratech Test Procedures ULTR-P001-2004 & ANSI C63.4 for method of measurements.

6.4.3. Test Equipment List

Test Instruments	Manufacturer	Model No.	Serial No.	Frequency Range
Spectrum Analyzer/ EMI Receiver	Hewlett Packard	HP 8593EM	3412A00103	9 kHz – 26.5 GHz
Transient Limiter	Hewlett Packard	11947A	310701998	9 kHz – 200 MHz 10 dB attenuation
L.I.S.N.	EMCO	3825/2	89071531	9 kHz – 200 MHz 50 Ohms / 50 μ H
24'(L) x 16'(W) x 8'(H) RF Shielded Chamber	Braden Shielding

6.4.4. Test Data

Plot 6.4.4.1
Power Line Conducted Emission
Line Voltage: 13.8 V DC
Line Tested: Pos.

177

Signal Freq (MHz) PK Amp GP Amp AV Amp

ACTV DET: PEAK
MEAS DET: PEAK GP AVG
MKR 560 kHz
28.77 dB μ V

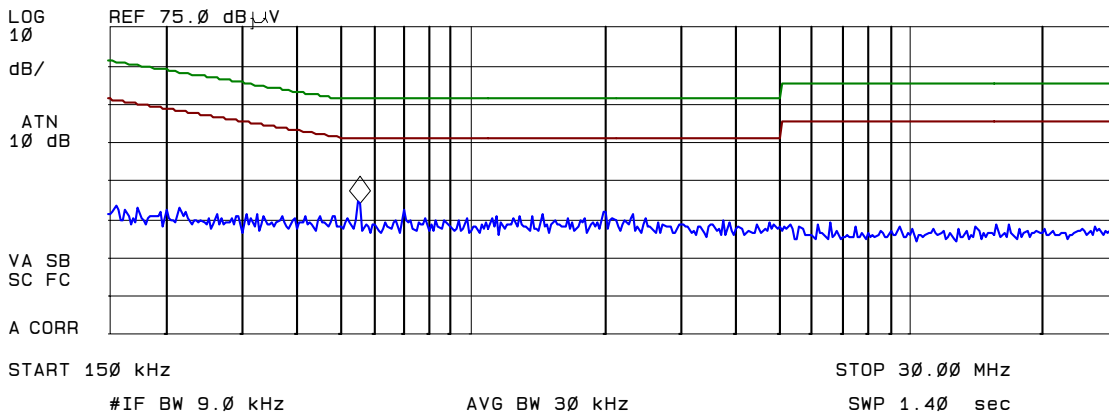

Plot 6.4.4.2
Power Line Conducted Emission
Line Voltage: 13.8 V DC
Line Tested: Neg.

177

Signal Freq (MHz) PK Amp GP Amp AV Amp

ACTV DET: PEAK
MEAS DET: PEAK GP AVG
MKR 560 kHz
28.61 dB μ V

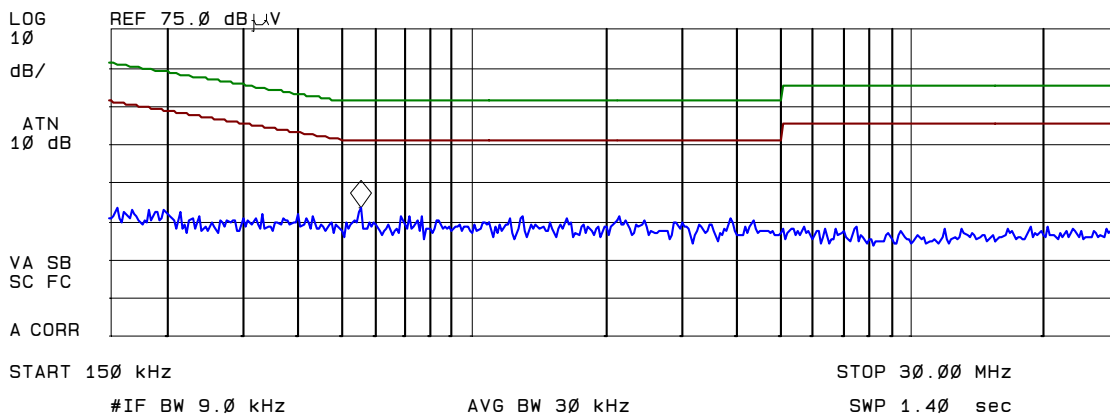

6.5. RADIATED EMISSIONS FROM CLASS B UNINTENTIONAL RADIATORS (DIGITAL DEVICES) [§ 15.109(a)]

6.5.1. Limits

The equipment shall meet the limits of the following table:

Frequency of Emission (MHz)	Section 15.109(a) Field Strength Limits at 3 Meters	
	(μ V/m)	(dB μ V/m)
30 – 88	100	40.0
88 – 216	150	43.5
216 – 960	200	46.0
Above 960	500	54.0

6.5.2. Method of Measurements

See Ultratech Test Procedures ULTR-P001-200 & ANSI C63.4 for method of measurements.

The spectrum shall be investigated from the lowest radio frequency signal generated or used in the device, without going below the lowest frequency for which a radiated emission limit is specified, up to the frequency shown in the following table:

Highest frequency generated or used in the device or on which the device operates or tunes (MHz)	Upper frequency of measurement range (MHz)
Below 1.705	30
1.705 - 108	1000
108 – 500	2000
500 -1000	5000
Above 1000	5th harmonic of the highest frequency or 40 GHz, whichever is lower

6.5.3. Test Equipment List

Test Instruments	Manufacturer	Model No.	Serial No.	Frequency Range
Spectrum Analyzer	Advantest	R3271	15050203	9 kHz – 26.5 GHz
Microwave Amplifier	Hewlett Packard	HP 83017A	3116A00661	1 GHz to 26.5 GHz
Active Loop Antenna	EMCO	6507	8906-1167	1 kHz – 30 MHz
Biconilog Antenna	EMCO	3143	1029	20 MHz to 2 GHz
Horn Antenna	EMCO	3155	9701-5061	1 GHz – 18 GHz
Horn Antenna with Mixer	EMCO	3160-09	1007	18 GHz – 26.5 GHz
Horn Antenna with Mixer	EMCO	3160-10	1001	26.5 GHz – 40 GHz

6.5.4. Test Data

Frequency (MHz)	E-Field at 3 m (dB μ V/m)	Detector Used (Peak/QP)	Antenna Plane (H/V)	Limit at 3 m (dB μ V/m)	Margin (dB)	Pass/Fail
42.30	31.6	Peak	V	40.0	-8.4	Pass
42.30	19.8	Peak	H	40.0	-20.2	Pass
47.10	34.7	Peak	V	40.0	-5.3	Pass
47.10	21.7	Peak	H	40.0	-18.3	Pass
51.30	32.5	Peak	V	40.0	-7.5	Pass
51.30	23.2	Peak	H	40.0	-16.8	Pass
63.00	30.8	Peak	V	40.0	-9.2	Pass
63.00	21.8	Peak	H	40.0	-18.2	Pass
75.90	33.7	Peak	V	40.0	-6.3	Pass
75.90	24.4	Peak	H	40.0	-15.6	Pass
78.60	33.9	Peak	V	40.0	-6.1	Pass
78.60	25.8	Peak	H	40.0	-14.2	Pass
83.40	30.5	Peak	V	40.0	-9.5	Pass
83.40	26.6	Peak	H	40.0	-13.4	Pass
88.80	28.9	Peak	V	43.5	-14.6	Pass
88.80	25.9	Peak	H	43.5	-17.6	Pass
116.40	31.2	Peak	V	43.5	-12.3	Pass
116.40	25.7	Peak	H	43.5	-17.8	Pass
133.80	30.4	Peak	V	43.5	-13.1	Pass
133.80	25.9	Peak	H	43.5	-17.6	Pass
138.90	29.5	Peak	V	43.5	-14.0	Pass
138.90	27.8	Peak	H	43.5	-15.7	Pass
162.40	25.8	Peak	V	43.5	-17.7	Pass
162.40	27.8	Peak	H	43.5	-15.7	Pass
179.90	22.4	Peak	V	43.5	-21.1	Pass
179.90	22.6	Peak	H	43.5	-20.9	Pass
233.00	23.8	Peak	V	46.0	-22.2	Pass
233.00	21.7	Peak	H	46.0	-24.3	Pass
254.70	22.6	Peak	V	46.0	-23.4	Pass
254.70	28.2	Peak	H	46.0	-17.8	Pass
372.60	29.5	Peak	V	46.0	-16.5	Pass
372.60	33.5	Peak	H	46.0	-12.5	Pass
447.70	26.5	Peak	V	46.0	-19.5	Pass
447.70	30.8	Peak	H	46.0	-15.2	Pass
621.10	27.4	Peak	V	46.0	-18.6	Pass
621.10	31.6	Peak	H	46.0	-14.4	Pass

Frequency (MHz)	E-Field at 3 m (dB μ V/m)	Detector Used (Peak/QP)	Antenna Plane (H/V)	Limit at 3 m (dB μ V/m)	Margin (dB)	Pass/Fail
651.00	26.0	Peak	V	46.0	-20.0	Pass
651.00	32.5	Peak	H	46.0	-13.5	Pass
696.90	27.7	Peak	V	46.0	-18.3	Pass
696.90	29.4	Peak	H	46.0	-16.6	Pass
746.20	28.2	Peak	V	46.0	-17.8	Pass
746.20	28.6	Peak	H	46.0	-17.4	Pass

Radiated Emissions Measurements @ 3m OFTS
 Icom Product: HF/VHF/UHF All Mode Transceiver, Model: IC-7000, FCC ID: AFJ242700

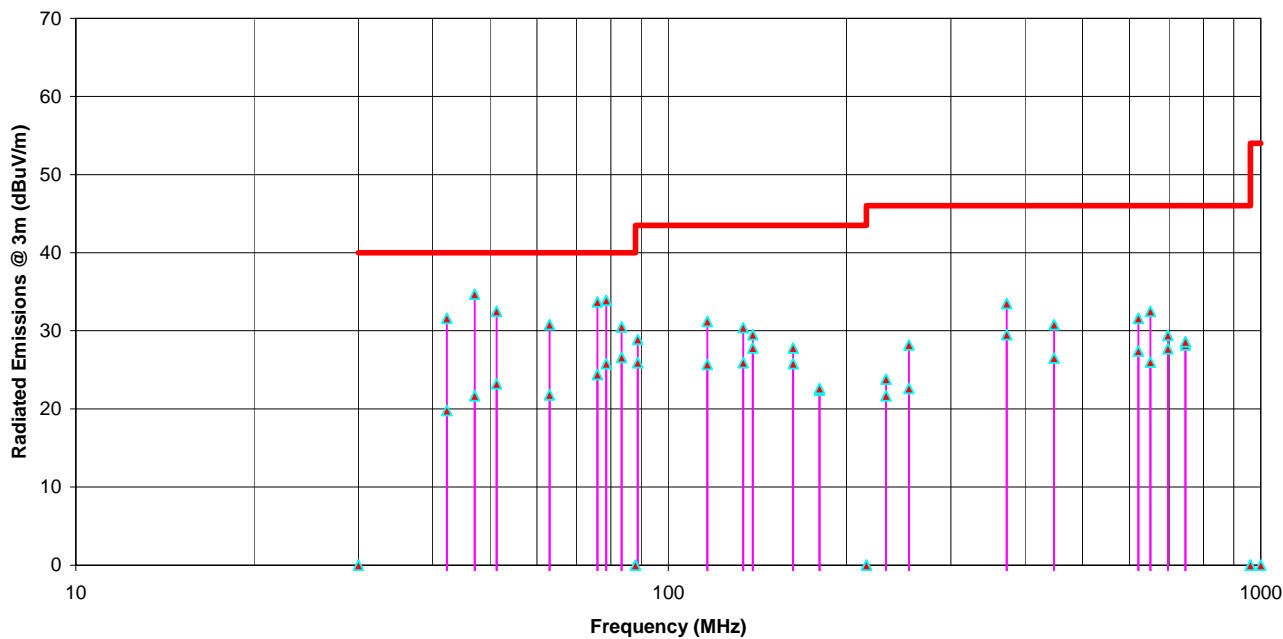

6.6. RECEIVER SPURIOUS/HARMONIC RADIATED EMISSIONS [§ 15.109(a)]

6.6.1. Limits

The equipment shall meet the limits of the following table:

Frequency of Emission (MHz)	Section 15.109(a) Field Strength Limits at 3 Meters	
	($\mu\text{V/m}$)	($\text{dB}\mu\text{V/m}$)
30 – 88	100	40.0
88 – 216	150	43.5
216 – 960	200	46.0
Above 960	500	54.0

6.6.2. Method of Measurements

See Ultratech Test Procedures ULTR-P001-200 & ANSI C63.4 for method of measurements.

The spectrum shall be investigated from the lowest radio frequency signal generated or used in the device, without going below the lowest frequency for which a radiated emission limit is specified, up to the frequency shown in the following table:

Highest frequency generated or used in the device or on which the device operates or tunes (MHz)	Upper frequency of measurement range (MHz)
Below 1.705	30
1.705 - 108	1000
108 – 500	2000
500 -1000	5000
Above 1000	5th harmonic of the highest frequency or 40 GHz, whichever is lower

6.6.3. Test Equipment List

Test Instruments	Manufacturer	Model No.	Serial No.	Frequency Range
Spectrum Analyzer	Advantest	R3271	15050203	9 kHz – 26.5 GHz
Microwave Amplifier	Hewlett Packard	HP 83017A	3116A0066 1	1 GHz to 26.5 GHz
Active Loop Antenna	EMCO	6507	8906-1167	1 kHz – 30 MHz
Biconilog Antenna	EMCO	3143	1029	20 MHz to 2 GHz
Horn Antenna	EMCO	3155	9701-5061	1 GHz – 18 GHz
Horn Antenna with Mixer	EMCO	3160-09	1007	18 GHz – 26.5 GHz
Horn Antenna with Mixer	EMCO	3160-10	1001	26.5 GHz – 40 GHz

6.6.4. Test Data

Remark: The FCC compliance requirements are exempted for receiver operating below 30 MHz and above 960 MHz. Therefore, tests will be performed at the receiver channel frequency in 30-960 MHz band.

6.6.4.1. Lowest Channel Frequency (30 MHz) of 30-200 MHz Band

Frequency (MHz)	E-Field at 3 m (dBµV/m)	Detector Used (Peak/QP)	Antenna Plane (H/V)	Limit at 3 m (dBµV/m)	Margin (dB)	Pass/Fail
154.48	30.5	Peak	H	43.5	-13.0	Pass
617.95	27.5	Peak	H	46.0	-18.5	Pass

The emissions were scanned from 30 MHz to 1 GHz and all emissions within 20 dB below the limits were recorded.

6.6.4.2. Middle Channel Frequency (115 MHz) of 30-200 MHz Band

Frequency (MHz)	E-Field at 3 m (dBµV/m)	Detector Used (Peak/QP)	Antenna Plane (H/V)	Limit at 3 m (dBµV/m)	Margin (dB)	Pass/Fail
239.49	29.5	Peak	H	46.0	-16.5	Pass
478.97	30.3	Peak	V	46.0	-15.7	Pass
478.97	29.8	Peak	H	46.0	-16.2	Pass
957.95	31.8	Peak	V	46.0	-14.2	Pass
957.95	30.2	Peak	H	46.0	-15.8	Pass

The emissions were scanned from 30 MHz to 1 GHz and all emissions within 20 dB below the limits were recorded.

6.6.4.3. Highest Channel Frequency (199.999999 MHz) of 30-200 MHz Band

Frequency (MHz)	E-Field at 3 m (dBµV/m)	Detector Used (Peak/QP)	Antenna Plane (H/V)	Limit at 3 m (dBµV/m)	Margin (dB)	Pass/Fail
324.49	28.4	Peak	H	46.0	-17.6	Pass
648.97	28.7	Peak	V	46.0	-17.3	Pass
648.97	33.9	Peak	H	46.0	-12.1	Pass

The emissions were scanned from 30 MHz to 1 GHz and all emissions within 20 dB below the limits were recorded.

6.6.4.4. Lowest Channel Frequency (400 MHz) of 400-470 MHz Band

Frequency (MHz)	E-Field at 3 m (dB μ V/m)	Detector Used (Peak/QP)	Antenna Plane (H/V)	Limit at 3 m (dB μ V/m)	Margin (dB)	Pass/Fail
524.49	34.9	Peak	V	46.0	-11.1	Pass
524.49	36.6	Peak	H	46.0	-9.4	Pass
1048.97	37.9	Peak	V	54.0	-16.1	Pass
1048.97	39.4	Peak	H	54.0	-14.6	Pass

The emissions were scanned from 30 MHz to 2 GHz and all emissions within 20 dB below the limits were recorded.

6.6.4.5. Middle Channel Frequency (435 MHz) of 400-470 MHz Band

Frequency (MHz)	E-Field at 3 m (dB μ V/m)	Detector Used (Peak/QP)	Antenna Plane (H/V)	Limit at 3 m (dB μ V/m)	Margin (dB)	Pass/Fail
559.49	35.1	Peak	V	46.0	-10.9	Pass
559.49	37.2	Peak	H	46.0	-8.8	Pass
1118.97	37.7	Peak	V	54.0	-16.3	Pass
1118.97	40.3	Peak	H	54.0	-13.7	Pass

The emissions were scanned from 30 MHz to 2.2 GHz and all emissions within 20 dB below the limits were recorded.

6.6.4.6. Highest Channel Frequency (470 MHz) of 400-470 MHz Band

Frequency (MHz)	E-Field at 3 m (dB μ V/m)	Detector Used (Peak/QP)	Antenna Plane (H/V)	Limit at 3 m (dB μ V/m)	Margin (dB)	Pass/Fail
594.50	36.6	Peak	V	46.0	-9.4	Pass
594.50	37.2	Peak	H	46.0	-8.8	Pass
1188.97	38.1	Peak	V	54.0	-15.9	Pass
1188.97	39.7	Peak	H	54.0	-14.3	Pass

The emissions were scanned from 30 MHz to 2.4 GHz and all emissions within 20 dB below the limits were recorded.

6.7. RECEIVER ANTENNA POWER SPURIOUS/HARMONIC CONDUCTED EMISSIONS [§15.111(a)]

6.7.1. Limits

Receivers that operate (tune) in the frequency range 30 to 960 Mhz and CB receivers that provides terminals for the connection of an external antenna may be tested to demonstrate compliance with the provisions of @ 15.109 with the antenna terminals shielded and terminated with a resistive termination equal to the impedance specified for the antenna, provided these receivers also comply with the following:- *With the receiver antenna terminal connected to a resistive termination equal to the impedance specified or employed for the antenna, the power at the antenna terminal at frequency within the range from 30 Mhz to 5th harmonic of the highest frequency shall not exceed 2.0 nanowatts (or -57 dBm @ 50 Ohm).*

6.7.2. Method of Measurements

See Ultratech Test Procedures ULTR-P001-200 & ANSI C63.4 for method of measurements.

The spectrum shall be investigated from the lowest radio frequency signal generated or used in the device, without going below the lowest frequency for which a radiated emission limit is specified, up to the frequency shown in the following table:

Highest frequency generated or used in the device or on which the device operates or tunes (MHz)	Upper frequency of measurement range (MHz)
Below 1.705	30
1.705 - 108	1000
108 – 500	2000
500 -1000	5000
Above 1000	5th harmonic of the highest frequency or 40 GHz, whichever is lower

6.7.3. Test Arrangement



6.7.4. Test Equipment List

Test Instruments	Manufacturer	Model No.	Serial No.	Frequency Range
Spectrum Analyzer	Advantest	R3271	15050203	100Hz - 26.5GHz

6.7.5. Test Data

Plot 6.7.5.1
Receiver Conducted Emissions at ANT1
Rx Frequency: 30MHz

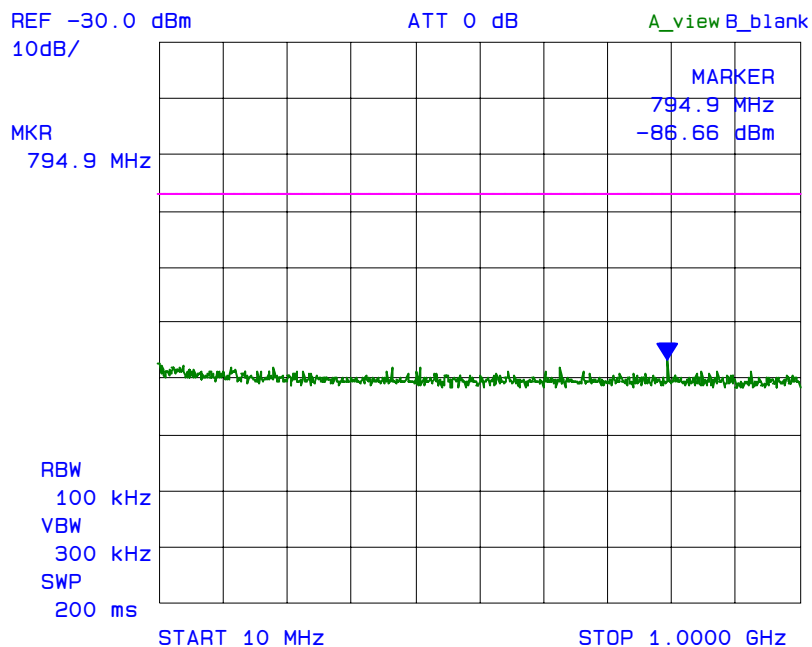

Plot 6.7.5.2
Receiver Conducted Emissions at ANT1
Rx Frequency: 115 MHz

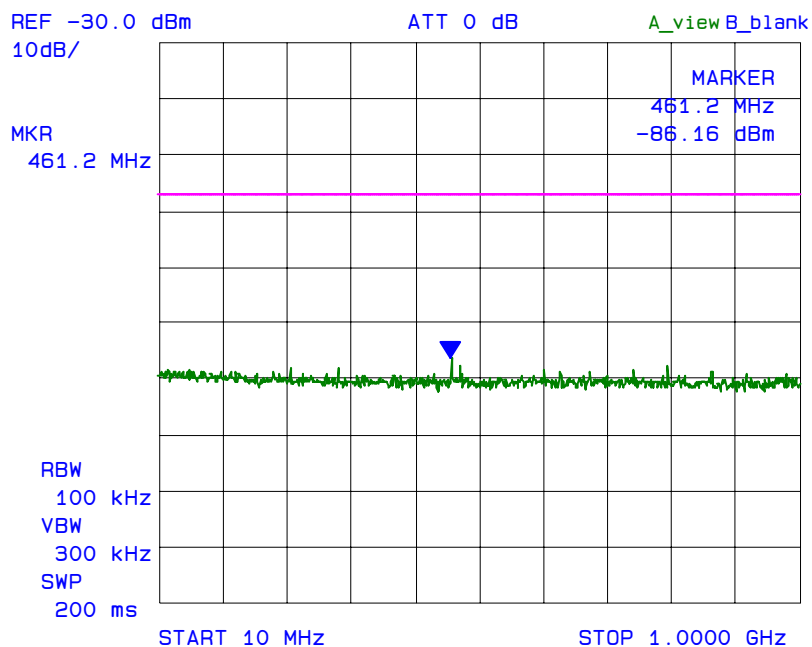

Plot 6.7.5.3
Receiver Conducted Emissions ANT1
Rx Frequency: 199.999999 MHz

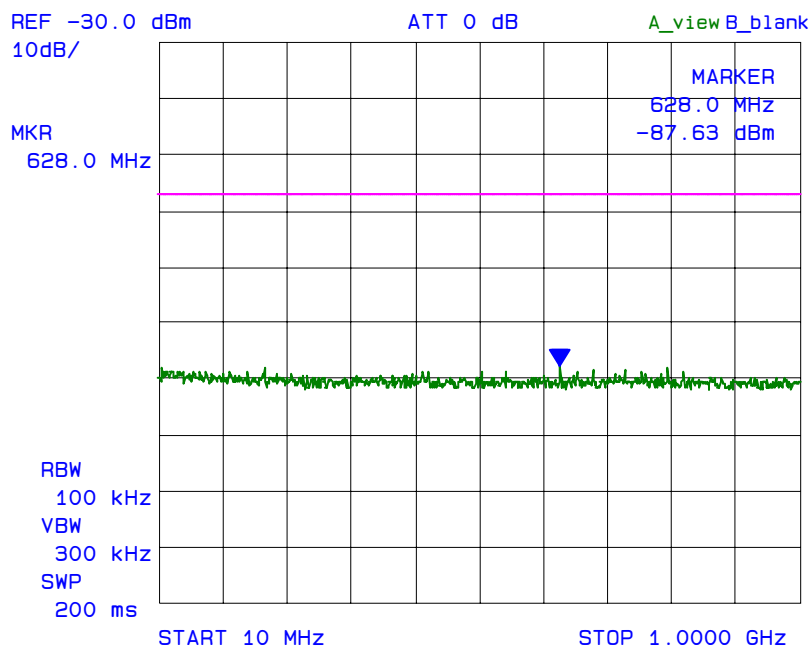

Plot 6.7.5.4
Receiver Conducted Emissions at ANT1
Rx Frequency: 400 MHz

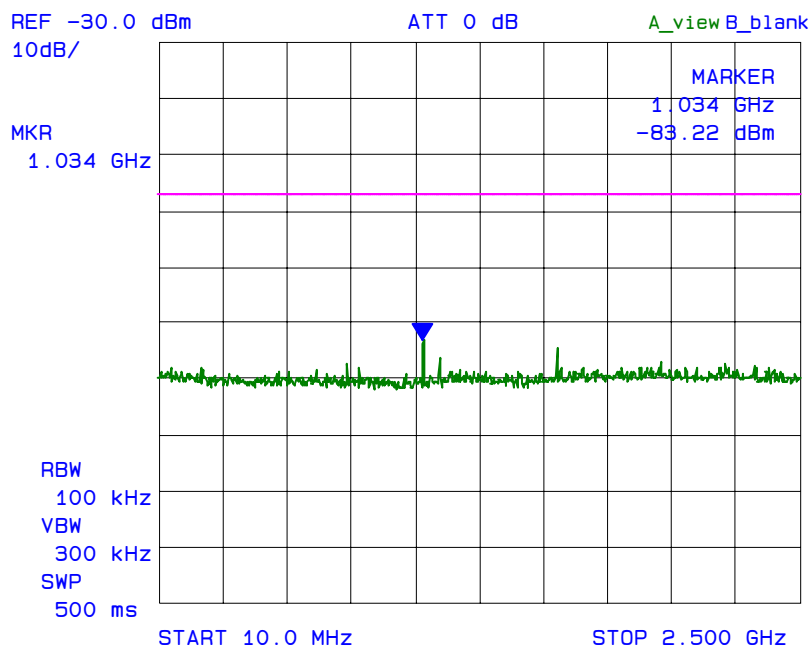

Plot 6.7.5.5
Receiver Conducted Emissions at ANT1
Rx Frequency: 435 MHz

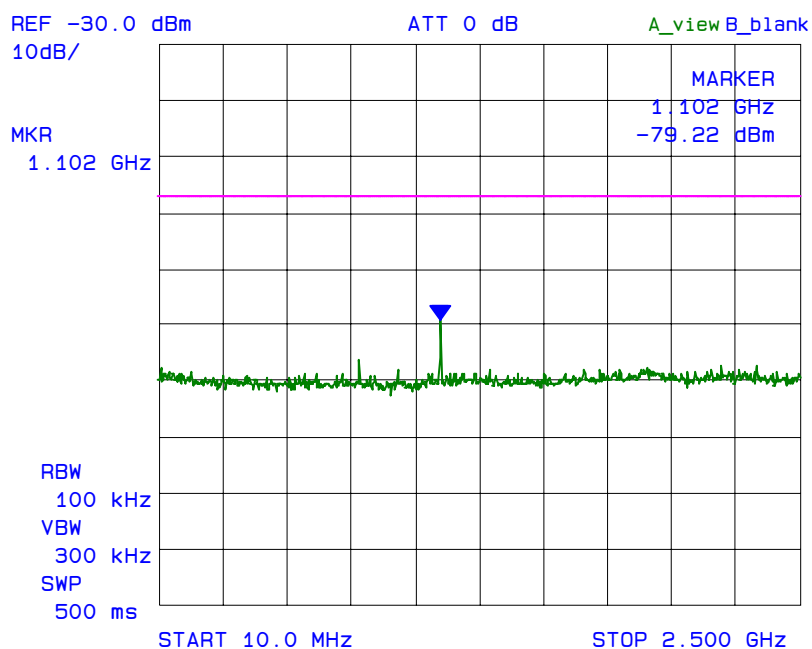

Plot 6.7.5.6
Receiver Conducted Emissions at ANT1
Rx Frequency: 470 MHz

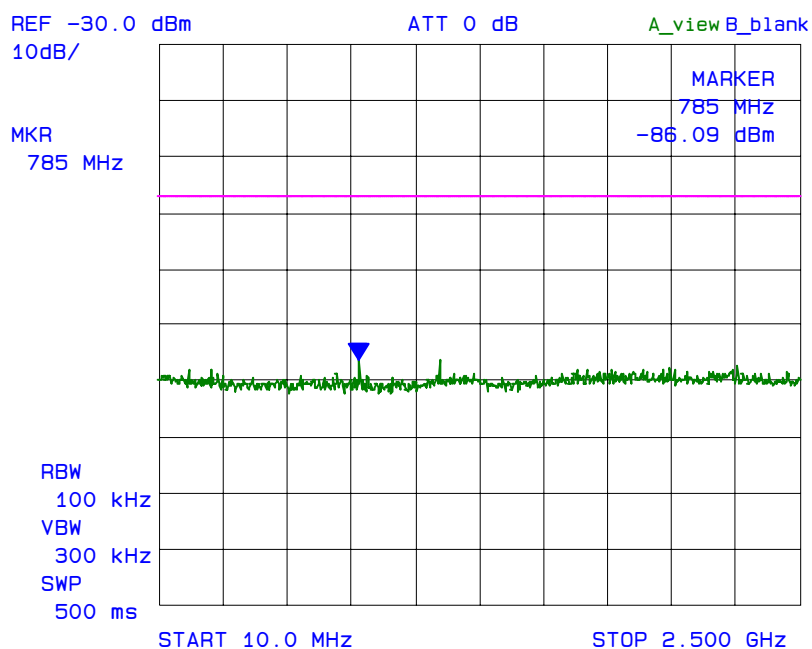

Plot 6.7.5.7
Receiver Conducted Emissions at ANT2
Rx Frequency: 30 MHz

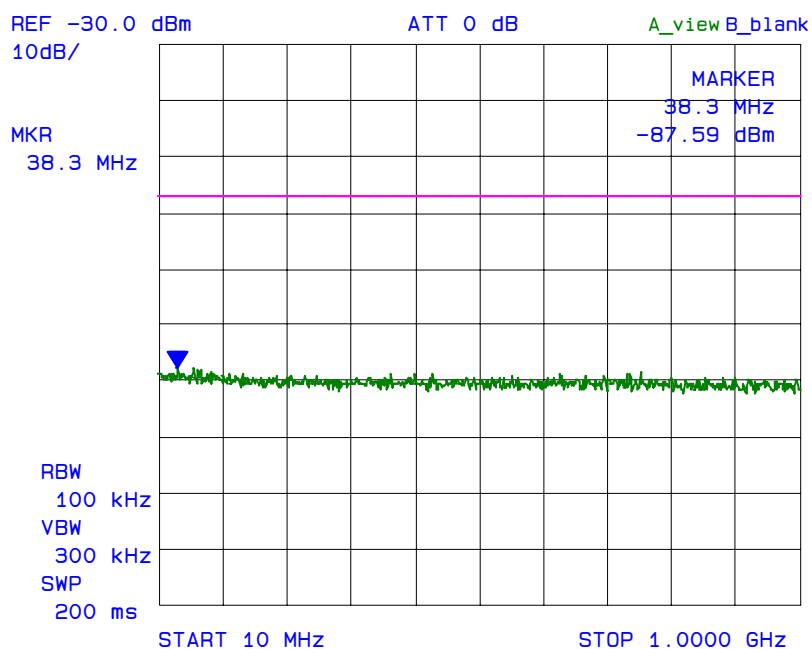

Plot 6.7.5.8
Receiver Conducted Emissions at ANT2
Rx Frequency: 115 MHz

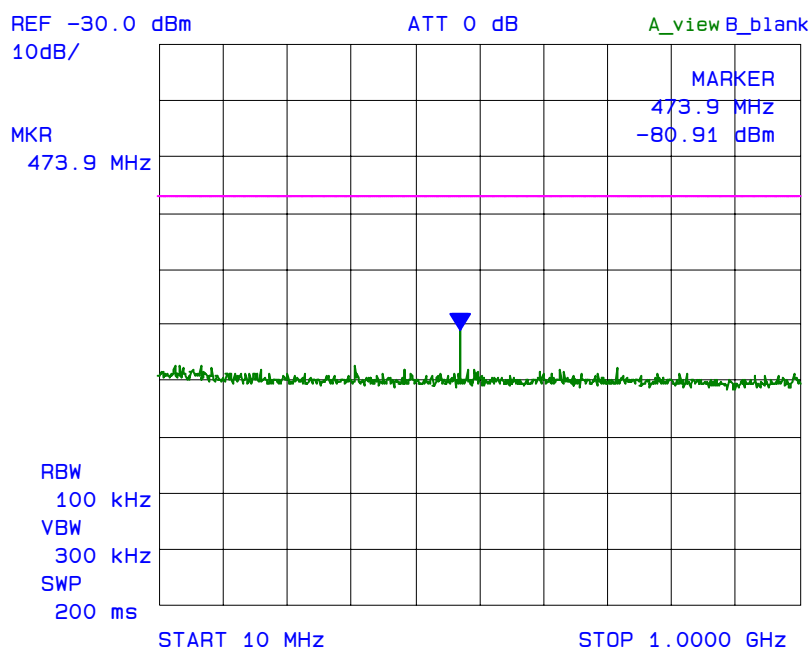

Plot 6.7.5.9
Receiver Conducted Emissions at ANT2
Rx Frequency: 199.999999 MHz

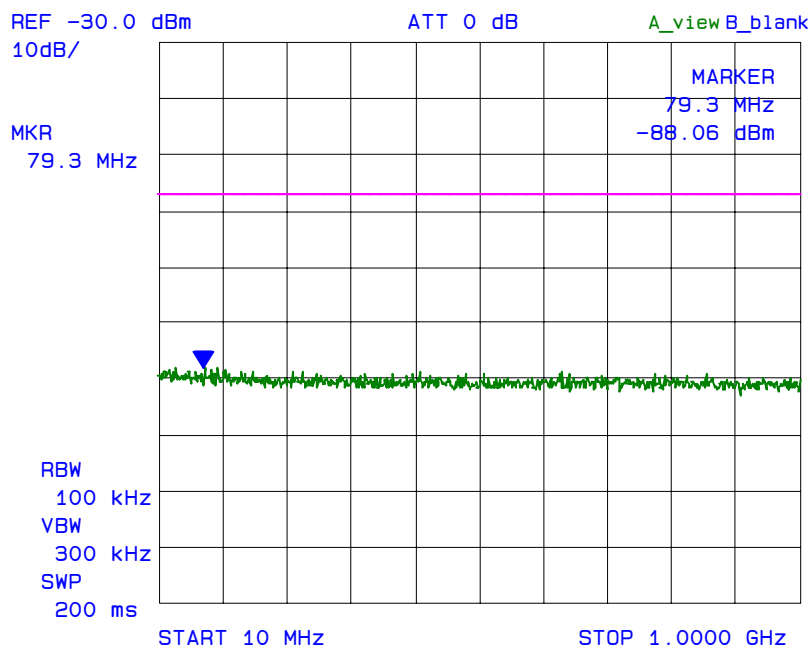

Plot 6.7.5.10
Receiver Conducted Emissions at ANT2
Rx Frequency: 400 MHz

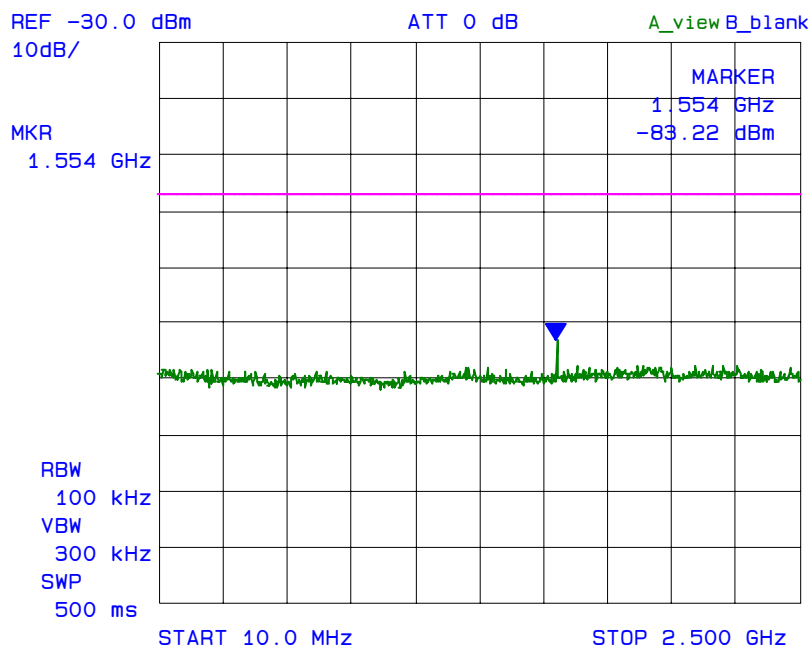

Plot 6.7.5.11
Receiver Conducted Emissions at ANT2
Rx Frequency: 435 MHz

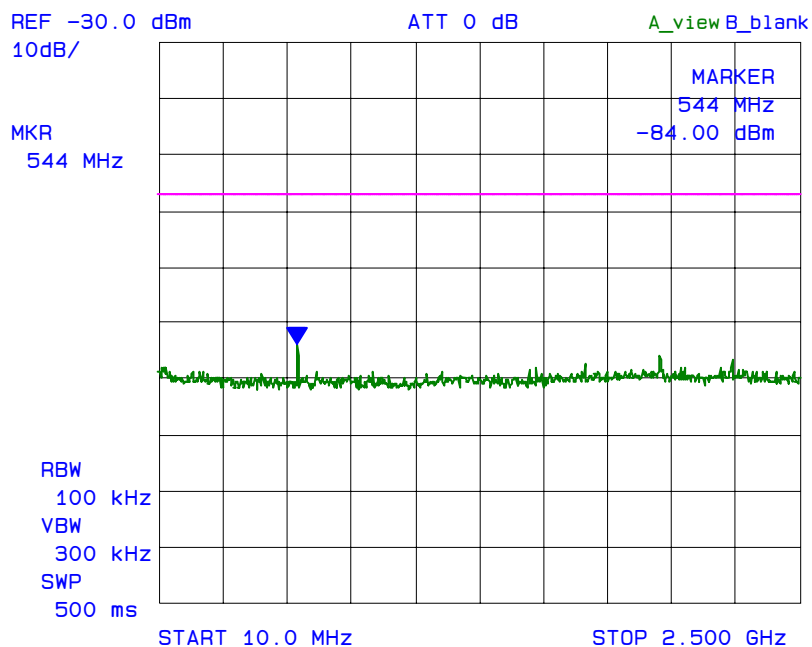

Plot 6.7.5.12
Receiver Conducted Emissions at ANT2
Rx Frequency: 470 MHz

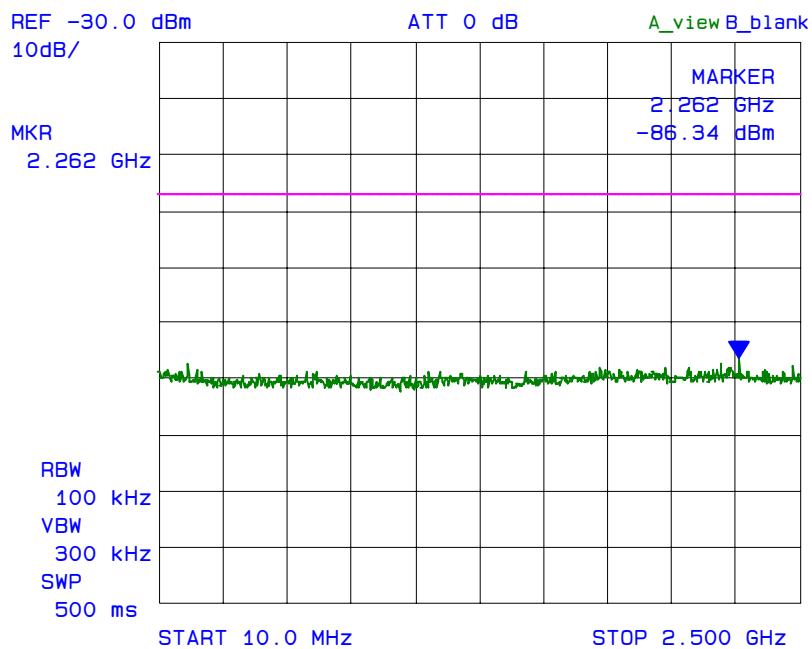

6.8. REQUIREMENTS FOR SCANNING RECEIVERS [§ 15.121]

6.8.1. FCC Rules

- (a) Except as provided in paragraph (c) of this section, scanning receivers and frequency converters designed or marketed for use with scanning receivers, shall:
- (1) Be incapable of operating (tuning), or readily being altered by the user to operate, within the frequency bands allocated to the Cellular Radiotelephone Service in part 22 of this chapter (cellular telephone bands). Scanning receivers capable of "readily being altered by the user" include, but are not limited to, those for which the ability to receive transmissions in the cellular telephone bands can be added by clipping the leads of, or installing, a simple component such as a diode, resistor or jumper wire; replacing a plug-in semiconductor chip; or programming a semiconductor chip using special access codes or an external device, such as a personal computer. Scanning receivers, and frequency converters designed for use with scanning receivers, also shall be incapable of converting digital cellular communication transmissions to analog voice audio.
 - (2) Be designed so that the tuning, control and filtering circuitry is inaccessible. The design must be such that any attempts to modify the equipment to receive transmissions from the Cellular Radiotelephone Service likely will render the receiver inoperable.
- (b) Except as provided in paragraph (c) of this section, scanning receivers shall reject any signals from the Cellular Radiotelephone Service frequency bands that are 38 dB or lower based upon a 12 dB SINAD measurement, which is considered the threshold where a signal can be clearly discerned from any interference that may be present.
- (c) Scanning receivers and frequency converters designed or marketed for use with scanning receivers, are not subject to the requirements of paragraphs (a) and (b) of this section provided that they are manufactured exclusively for, and marketed exclusively to, entities described in 18 U.S.C. 2512(2), or are marketed exclusively as test equipment pursuant to Sec. 15.3(dd)
- (d) Modification of a scanning receiver to receive transmissions from Cellular Radiotelephone Service frequency bands will be considered to constitute manufacture of such equipment. This includes any individual, individuals, entity or organization that modifies one or more scanners. Any modification to a scanning receiver to receive transmissions from the Cellular Radiotelephone Service frequency bands voids the certification of the scanning receiver, regardless of the date of manufacture of the original unit. In addition, the provisions of Sec. 15.23 shall not be interpreted as permitting modification of a scanning receiver to receiver Cellular Radiotelephone Service transmissions.
- (e) Scanning receivers and frequency converters designed for use with scanning receivers shall not be assembled from kits or marketed in kit form unless they comply with the requirements in paragraph (a) through (c) of this section.

- (f) Scanning receivers shall have a label permanently affixed to the product, and this label shall be readily visible to the purchaser at the time of purchase. The label shall read as follows:

WARNING: MODIFICATION OF THIS DEVICE TO RECEIVE CELLULAR RADIOTELEPHONE SERVICE SIGNALS IS PROHIBITED UNDER FCC RULES AND FEDERAL LAW.

- (1) ``Permanently affixed" means that the label is etched, engraved, stamped, silkscreened, indelible printed or otherwise permanently marked on a permanently attached part of the equipment or on a nameplate of metal, plastic or other material fastened to the equipment by welding, riveting, or permanent adhesive. The label shall be designed to last the expected lifetime of the equipment in the environment in which the equipment may be operated and must not be readily detachable. The label shall not be a stick-on, paper label.
- (2) When the device is so small that it is not practicable to place the warning label on it, the information required by this paragraph shall be placed in a prominent location in the instruction manual or pamphlet supplied to the user and shall also be placed on the container in which the device is marketed. However, the FCC identifier must be displayed on the device.

6.8.2. Declaration for Compliance with FCC §15.121

Scanning Receiver Requirements	Comments
§ 15.121(a)(1)	See manufacturer's attestation letter describing the design features that prevent modification of the scanning receiver to receiver cellular transmissions
§ 15.121(a)(2)	See manufacturer's attestation letter describing the design steps taken to make tuning, control and filtering circuitry inaccessible.
§ 15.121(b)	Compliance with this requirement is addressed in this test report.
§ 15.121(c)	Not applicable.
§ 15.121(d)	See warning statement pursuant to §15.21 in the instruction manual.
§ 15.121(e)	This scanning receiver will not be assembled from kits or marketed in kit form.
§ 15.121(f)	See label for warning against modifications to allow cellular reception.

6.9. SCANNING RECEIVERS CELLULAR BAND REJECTION [§ 15.121(b)]

6.9.1. Limits

Except as provided in paragraph (c) of this section, scanning receivers shall reject any signals from the Cellular Radiotelephone Service frequency bands that are 38 dB or lower based upon a 12 dB SINAD measurement, which is considered the threshold where a signal can be clearly discerned from any interference that may be present.

6.9.2. Method of Measurements

- (1) Connected the EUT as shown in the following block diagram
- (2) Apply a standard RF signal to the receiver input port
- (3) Adjust the audio output signal of the receiver to it's rated value with the distortion less than 10%
- (4) Adjust the RF Signal Generator Output Power to produce 12 dB SINAD without the audio output power dropping by more than 3 dB
- (5) Repeat step (4) at lowest, middle and highest channel frequencies across all cellular base station band to establish a reference sensitivity level. The reference sensitivity taken was the lowest or worse-case sensitivity for all of the bands.
- (6) Adjust the RF Signal Generator output to a level of +60 dB above the reference sensitivity obtained in step (5)
- (7) Set the Receiver squelch threshold (the signal required to open the squelch) no greater than +20 dB above the reference sensitivity level.
- (8) Put the receiver in a scanning mode and allow it to scan across it's complete receive range
- (9) If the receiver unsquelched or stopped on any frequency, the display frequency is recorded. The signal generator output level was then adjusted until 12 dB SINAD from the receiver was produced. The signal generator level associated with this response was also noted.
- (10) Repeat this procedure for 3 frequencies in the cellular base station transmit band.
- (11) The difference between the signal generator output for any response recorded and reference sensitivity is the rejection ratio

6.9.3. Test Arrangement

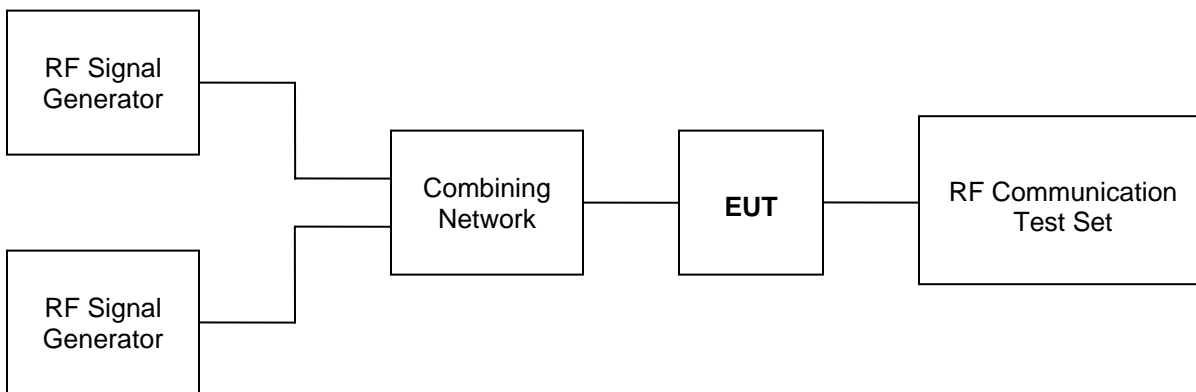

6.9.4. Test Equipment List

Test Instruments	Manufacturer	Model No.	Serial No.	Frequency Range
RF Communication Test Set	Hewlett-Packard	8920B	US39064699	RF 30MHz-1GHz AF DC-25 kHz
RF Signal Generator	Fluke	6061A	4770301	10 kHz – 1050 MHz
RF Signal Generator	Fluke	6061A	5130586	10 kHz – 1050 MHz
Combining Network	Mini-Circuits	ZFSC-3-4	15542	1 MHz – 1000 MHz

6.9.5. Test Data

6.9.5.1. EUT's Operating Mode: FM

EUT's Scanning Frequency Band (MHz)	Cellular Transmitter Test Frequencies (MHz)	RF Input Signal Level @ Cellular Frequencies (dBm)	Worst-case Sensitivity for 12 dB SINAD (dBm)	Rejection Ratio (dB)	Maximum Rejection Ratio Limit (dB)
28 - 199.999999 400 - 470	824.04, 836.40, 848.97, 869.04, 882.04, 893.97	-40	-85	<-45	-38
There is no spurious response detected within the above frequency bands with the Rejection Ratio of at least -45 dB.					

6.9.5.2. EUT's Operating Mode: AM

EUT's Scanning Frequency Band (MHz)	Cellular Transmitter Test Frequencies (MHz)	RF Input Signal Level @ Cellular Frequencies (dBm)	Worst-case Sensitivity for 12 dB SINAD (dBm)	Rejection Ratio (dB)	Maximum Rejection Ratio Limit (dB)
0.5 - 199.999999 400 - 470	824.04, 836.40, 848.97, 869.04, 882.04, 893.97	-40	-86	<-46	-38
There is no spurious response detected within the above frequency bands with the Rejection Ratio of at least -46 dB.					

6.9.5.3. EUT's Operating Mode: WFM

EUT's Scanning Frequency Band (MHz)	Cellular Transmitter Test Frequencies (MHz)	RF Input Signal Level @ Cellular Frequencies (dBm)	Worst-case Sensitivity for 12 dB SINAD (dBm)	Rejection Ratio (dB)	Maximum Rejection Ratio Limit (dB)
76 - 108	824.04, 836.40, 848.97, 869.04, 882.04, 893.97	-40	-101	<-61	-38
There is no spurious response detected within the above frequency band with the Rejection Ratio of at least -61 dB.					

6.9.5.4. EUT's Operating Mode: SSB

EUT's Scanning Frequency Band (MHz)	Cellular Transmitter Test Frequencies (MHz)	RF Input Signal Level @ Cellular Frequencies (dBm)	Worst-case Sensitivity for 12 dB SINAD (dBm)	Rejection Ratio (dB)	Maximum Rejection Ratio Limit (dB)
1.8 - 199.999999 400 - 470	824.04, 836.40, 848.97, 869.04, 882.04, 893.97	-40	<-110	<-70	-38

There is no spurious response detected within the above frequency bands with the Rejection Ratio of at least -70 dB.

EXHIBIT 7. MEASUREMENT UNCERTAINTY

The measurement uncertainties stated were calculated in accordance with the requirements of NIST Technical Note 1297 and LAB 34

7.1. LINE CONDUCTED EMISSION MEASUREMENT UNCERTAINTY

CONTRIBUTION (Line Conducted)	PROBABILITY DISTRIBUTION	UNCERTAINTY (dB)	
		9-150 kHz	0.15-30 MHz
EMI Receiver specification	Rectangular	± 1.5	± 1.5
LISN coupling specification	Rectangular	± 1.5	± 1.5
Cable and Input Transient Limiter calibration	Normal (k=2)	± 0.3	± 0.5
Mismatch: Receiver VRC $\Gamma_1 = 0.03$ LISN VRC $\Gamma_R = 0.8(9 \text{ kHz}) 0.2(30 \text{ MHz})$ Uncertainty limits $20\text{Log}(1 \pm \Gamma_1 \Gamma_R)$	U-Shaped	± 0.2	± 0.3
System repeatability	Std. deviation	± 0.2	± 0.05
Repeatability of EUT	--	--	--
Combined standard uncertainty	Normal	± 1.25	± 1.30
Expanded uncertainty U	Normal (k=2)	± 2.50	± 2.60

Sample Calculation for Measurement Accuracy in 150 kHz to 30 MHz Band:

$$uc(y) = \sqrt{\sum_{i=1}^m u_i^2(y)} = \pm \sqrt{(1.52 + 1.52)/3 + (0.5/2)^2 + (0.05/2)^2 + 0.352} = \pm 1.30 \text{ dB}$$

$$U = 2uc(y) = \pm 2.6 \text{ dB}$$

7.2. RADIATED EMISSION MEASUREMENT UNCERTAINTY

CONTRIBUTION (Radiated Emissions)	PROBABILITY DISTRIBUTION	UNCERTAINTY (\pm dB)	
		3 m	10 m
Antenna Factor Calibration	Normal (k=2)	± 1.0	± 1.0
Cable Loss Calibration	Normal (k=2)	± 0.3	± 0.5
EMI Receiver specification	Rectangular	± 1.5	± 1.5
Antenna Directivity	Rectangular	± 0.5	± 0.5
Antenna factor variation with height	Rectangular	± 2.0	± 0.5
Antenna phase center variation	Rectangular	0.0	± 0.2
Antenna factor frequency interpolation	Rectangular	± 0.25	± 0.25
Measurement distance variation	Rectangular	± 0.6	± 0.4
Site imperfections	Rectangular	± 2.0	± 2.0
Mismatch: Receiver VRC $\Gamma_1 = 0.2$ Antenna VRC $\Gamma_R = 0.67(\text{Bi}) 0.3 (\text{Lp})$ Uncertainty limits $20\text{Log}(1+\Gamma_1\Gamma_R)$	U-Shaped	+1.1 -1.25	± 0.5
System repeatability	Std. Deviation	± 0.5	± 0.5
Repeatability of EUT		-	-
Combined standard uncertainty	Normal	+2.19 / -2.21	+1.74 / -1.72
Expanded uncertainty U	Normal (k=2)	+4.38 / -4.42	+3.48 / -3.44

Calculation for maximum uncertainty when 3m biconical antenna including a factor of k = 2 is used:

$$U = 2uc(y) = 2x(+2.19) = +4.38 \text{ dB} \quad \text{And} \quad U = 2uc(y) = 2x(-2.21) = -4.42 \text{ Db}$$